

# 納入仕様書

## Product Specifications

新規(含:新規部品追加)  
New application (Incl.: new part(s) adding)

貴社部品名  
Customer's parts name \_\_\_\_\_

仕様変更 ( 貴社  納入者)  
Specification revisio by customer by supplier)

貴社部品番号  
Customer's parts number \_\_\_\_\_

弊社部品名 USS180BMVTC3(AE)  
Supplier's parts name USS180BMVTC3(E)

弊社部品番号 F-4994-254-6(Boat)  
Supplier's parts number F-4994-254-7(Air)

### 【受領印欄 Receipt & Acceptance】

納入仕様書への受領サインにより、貴社は、貴社が納入仕様書を遵守されなかったことに起因して、貴社及びその他の第三者に生じた損害・損失等に関して、特別損害、間接損害、懲罰的損害等を含め、ソニーは一切の責任を負わないことにつき同意したものとみなされます。

PLEASE NOTE THAT CUSTOMER AGREES BY SIGNATURE ON THE PRODUCT SPECIFICATION THAT IN NO EVENT SHALL SONY BE LIABLE TO CUSTOMER AND ANY THIRD PARTY FOR ANY DAMAGES OR LOSSES, INCLUDING BUT NOT LIMITED TO, ANY SPECIAL INCIDENTAL, CONSEQUENTIAL OR PUNITIVE DAMAGES OR LOSSES, COMPENSATION, REIMBURSEMENT, WHICH MAY BE CAUSED BY CUSTOMER'S NON-OBSERVANCE HEREOF.

納入者 Supplier  
ソニー株式会社  
デバイスソリューション事業本部  
Sony Corporation  
Device Solutions Business Group  
  
〒108-0075  
東京都港区港南 1-7-1  
1-7-1 Konan, Minato-ku, Tokyo, 108-0075 Japan

申請年月日 2016年 3月 25日  
Date of application (Y/M/D) \_\_\_\_\_

責任者名(押印 or 署名)  
Person responsible 

技術担当名 寺内  
Person in charge of engineering \_\_\_\_\_

営業担当名 砂本  
Person in charge of sales \_\_\_\_\_

仕様書番号 Spec. No.	KU22129	Ver.	2.0
--------------------	---------	------	-----

# 納入仕様書

Product Specifications

貴社名 : Batterien-Montage- Zentrum GmbH.  
Customer's name : \_\_\_\_\_

貴社部品名 : \_\_\_\_\_  
Customer's parts name \_\_\_\_\_

貴社部品番号 : \_\_\_\_\_  
Customer's parts number \_\_\_\_\_

ソニー部品名 : USS180BMVTC3(AE)  
SONY parts name : USS180BMVTC3(E)  
\_\_\_\_\_

 ソニー部品番号 : F-4994-254-6 (Boat)  
SONY parts number : F-4994-254-7 (Air)  
\_\_\_\_\_

承認 Approved by	確認 Checked by	作成 Prepared by
		





**DANGER**

弊社のバッテリーセル製品はセル単体での販売や使用を前提とするものではありません  
 THESE CELLS ARE NOT INTENDED FOR INDIVIDUAL SALE OR USE.  
 安全措置や安全構造の施されているパックや製品への組込部品としてのみご使用いただけます  
 THESE CELLS MAY ONLY BE USED WITH ASSEMBLY OF BATTERY PACKS.

弊社のバッテリーセル製品をセル単体で使用又は販売された場合、  
 深刻な身体上の危険をもたらすおそれがあります  
 USE OF THESE CELLS INDIVIDUALLY PRESENTS A SERIOUS RISK OF PERSONAL INJURY OR DEATH.

**変更履歴**

## History of revisions

変更年月日 Date		変更事項 Description	承認 Approved by	作成 Prepared by
Ver.1.0	2014. 03.13	1 <sup>st</sup> issue	2014.03.14 K.Oiyama	2014.03.13 H.Kaneko
Ver.2.0 	2016. 03.23	<ul style="list-style-type: none"> <li>•Change of SONY parts number. ソニー部品番号の変更</li> <li>•Product Specifications changes related to Sony standard change. ソニー標準の関連に変更した納入仕様書に変更</li> <li>•Item additions and corrections. 項目の追加と修正</li> </ul> 【Add】追加 2. Cell Rating セル定格 Shipment state definition change of the cell. セルの出荷状態の定義変更 6.8 Warning Message 9.2.2 Air transport specifications 9.4.2 Air transport specifications Addition of CAO mark. CAO マークの追加 【Correction】修正 5.5.1 Open-Circuit Voltage. 開路電圧 Specification change. 3.40-3.80V ⇒ 3.400-3.616V 規格値変更 3.40-3.80V ⇒ 3.400-3.616V 6. Identification and Marking セル表示 Change of Fig.1. Fig.1 の変更 6.5 Lot Number ロットナンバー Notation change of year. 年の表記変更		

## Contents 目次

1. General 概要 .....	4
1.1 Scope 適用範囲 .....	4
1.2 Product Category 製品カテゴリ .....	4
1.3 Cell Type 機種名 .....	4
1.4 Cell designation based on IEC61960 IEC61960 に基づく呼び方 .....	4
1.5 Applicable Safety Standard 適用安全規格 .....	4
2. Cell Rating セル定格 .....	4
2.1 Rated Capacity 定格容量 .....	4
2.2 Maximum Charge Voltage 最大充電電圧 .....	4
2.3 Cut Off Voltage 放電終止下限電圧 .....	4
2.4 Continuous Maximum Charge Current 連続最大充電電流 .....	4
2.5 Continuous Maximum Discharge Current 連続最大放電電流 .....	4
2.6 Allowable Environment Temperature 使用雰囲気温度 .....	4
2.7 Weight 質量 .....	4
2.8 Cell Temperature Spec セル温度規格 .....	5
3. Cell Nominal Value セル公称値 .....	5
3.1 Nominal Capacity 公称容量 .....	5
3.2 Nominal Voltage 公称電圧 .....	5
3.3 Charge Voltage 充電電圧 .....	5
3.4 Energy Density エネルギー密度 .....	5
4. Shape / Dimension and Appearance 形状 / 寸法と外観 .....	5
4.1 Shape/Dimension 形状/寸法 .....	5
4.2 Appearance 外観 .....	5
5. Performance 性能 .....	6
5.1 Standard Test Condition 標準試験条件 .....	6
5.2 Testing Instruments or Apparatus 試験計器および器具 .....	6
5.3 Standard Charge definition 標準充電 .....	6
5.4 Standard Discharge definition 標準放電 .....	6
5.5 Electrical Performance 電気的性能 .....	7~8
5.6 Reliability 信頼性 .....	9
6. Identification and Marking セル表示 .....	10
6.1 Manufacturer Name (Trade name) 製造社名 .....	10
6.2 Trade Mark 登録機種名 .....	10
6.3 Plant 製造所 .....	10
6.4 Specification 仕様 .....	10
6.5 Lot Number ロット、セル製造年月日 .....	10
6.6 UL Marking ULマーク .....	10
6.7 2 Dimensional Code 2次元コード .....	10
6.8 Warning Message .....	11
7. Outline 外形 .....	11
8. Caution 注意事項 .....	12
8.1 Caution for installing the battery into the pack パック組立 .....	12
8.2 Caution for the battery and the pack 単セルおよびパックに関する注意事項 .....	12~13
8.3 Storage 保存 .....	13
8.4 Prohibition Clause 禁止事項 .....	14
8.5 Note 補足 .....	14
9. Packing 梱包仕様 .....	15
9.1 Packing Instruction 梱包仕様図 .....	15
9.2 Printing Instruction for Master Carton マスターカートン印刷仕様 .....	16
9.3 Parts name marking 品名表示 .....	17
9.4 Packing Instruction for Pallet パレット梱包仕様 .....	18

## Lithium-Ion Battery Specifications リチウムイオンバッテリー仕様

## 1. General 概要

## 1.1 Scope 適用範囲

This specification is applied to Lithium-Ion Rechargeable Batteries provided by Sony.  
本仕様書はソニー製リチウムイオンバッテリーに適用する。

## 1.2 Product Category 製品カテゴリー

Lithium-Ion Rechargeable Battery リチウムイオンバッテリー

## 1.3 Cell Type 機種名

US18650VTC3

## 1.4 Cell designation based on IEC61960. IEC61960 に基づく呼び方

INR19/66

## 1.5 Applicable Safety Standard 適用安全規格 (Registration name : US18650VTC3)

UL1642: File No.MH12566  
IEC62133 1st / 2nd Edition  
Taiwan Commodity Inspection Act (CNS 15364)

## 2. Cell Rating セル定格

Item 項目	Rating 定格	Note 備考
2.1 Rated Capacity 定格容量	1500mAh	Discharge at 0.2ItA, 2.5V cutoff after Standard Charge 0.2ItA, 2.5V 終止放電での容量規格値、 充電は標準充電
2.2 Maximum Charge Voltage 最大充電電圧	4.25V	
2.3 Cut Off Voltage 放電終止下限電圧	2.5V	
2.4 Continuous Maximum Charge Current 連続最大充電電流	10.0A	
2.5 Continuous Maximum Discharge Current 連続最大放電電流	30.0A	
2.6 Allowable Environment Temperature 使用雰囲気温度	Charge 充電	Refer to the cell temperature spec of 2.8 for cell surface temperature. セル表面温度に関しては 2.8 のセル温度規格を参照のこと。
	Discharge 放電	
2.7 Weight 質量	45.0+/-1.5 g	

※ Cell condition at shipment SOC (State Of Charge ) not exceed 30% of rated capacity.  
セルの出荷状態は 定格容量の SOC (State Of Charge 充電状態) 30%を超えない。

## 2.8 Cell Temperature Spec セル温度規格

2.8.1 Charge Conditions 充電条件 / This item is recommendation 本規格は推奨とする						
Temperature Range / Cell Surface Temperature Range 温度範囲 / セル表面温度				Upper Limited Charging Voltage 上限充電電圧	Maximum Charging Current 最大充電電流	Charging Current Recommendation 推奨充電電流
1	Low Charging Temperature Range 低温度域	0°C ≤ T < 10°C	A	4.25V	1.50A	0.75A
			B	4.15V	4.00A	1.50A
2	Standard Charging Temperature Range 標準温度域	10°C ≤ T ≤ 45°C		4.25V	4.00A	1.50A
3	High Charging Temperature Range 高温度域	45°C < T ≤ 60°C		4.15V	4.00A	1.50A

At Low Charging Temperature range, condition A and B are both available.

Recommended condition is B.

低温度域は条件 A または条件 B のどちらかを選択できる。推奨は条件 B。

2.8.2 Discharge Conditions 放電条件
Discharge at cell surface temperature below 80°C. セル表面温度が 80°C 以下で放電をおこなうこと。

## 3. Cell Nominal Value セル公称値

Item 項目	Nominal 公称	Note 備考
3.1 Nominal Capacity 公称容量	1600mAh	Discharge at 0.2ItA, 2.5V cutoff after Standard Charge 0.2ItA, 2.5V 終止放電での容量規格値、充電は標準充電
3.2 Nominal Voltage 公称電圧	3.7V	
3.3 Charge Voltage 充電電圧	4.20V	
3.4 Energy Density エネルギー密度	330Wh/l	

## 4. Shape/Dimension and Appearance 形状 / 寸法と外観

### 4.1 Shape/Dimension (Ref. P11 7. Outline) 形状 / 寸法 (参照: P11 7. 外形)

Diameter of crimp クリンプ部外形	18.20 +0.15 / -0.20 mm
Diameter of trunk 胴部外形	18.10 +/- 0.20 mm (excluding wrinkle on the tube) (チューブ収縮シワを含まない)
Total Height 総高	64.90 +/- 0.20 mm

### 4.2 Appearance 外観

It shall be free from any defects such as remarkable scratches, breaks, cracks, discoloration, leakage, or deformation. It shall be clean, and have equality and product value.

著しい傷、破損、ひび、変色、液漏れ、変形のないものとし、清潔、均一で製品価値を持つものとする。

## 5. Performance 性能

### 5.1 Standard Test Condition 標準試験条件

Test condition shall be at 23 +/- 2degC and 65 +/- 20% R.H. However, temperature 15 ~ 30°C, humidity

25~85% is acceptable as far as the test reliability is assured.

温度 23±2°C、湿度 65±20%とする。但し、疑義の生じない限りにおいては、温度 15~30°C、湿度 25~85%の範囲において試験を行って良い。

### 5.2 Testing Instrument or Apparatus 試験計器及び器具

#### 5.2.1 Dimension Measuring Instrument 寸法測定器

The dimension measurement shall be implemented by instruments with equal or more precision scale of 0.01mm specified by JIS B 7502(outside micrometer) or JIS B 7503(dial gauge).

寸法測定には JIS B7502(外側マイクロメーター)、または JIS B7503(ダイヤルゲージ)に規定する目盛り 0.01mm のもの、または同等以上の精度を有する測定器を使用する。

#### 5.2.2 Voltmeter and Ammeter 電圧計及び電流計

Voltmeters and ammeters shall be equal or more precision instruments specified by JIS C 1102

(Indication Electric Instrument Level 0.5).

JIS C1102(表示電気計器 0.5 級)に規定するもの、または同等以上の精度を有する測定器を使用する。

### 5.3 Standard Charge definition 標準充電

Charging at a constant voltage of 4.20V (+/-0.005V) and a constant current of 1.5A for 2.5 hours in 23 +/-2°C atmosphere.

23±2°Cの雰囲気中で 4.20V(±0.005V)、1.5A の定電圧、定電流で 2.5 時間充電することをいう。

### 5.4 Standard Discharge definition 標準放電

Discharging at a constant current of 1.5A down to 2.5V in 23 +/-2°C atmosphere.

23±2°Cの雰囲気中で 1.5A 定電流にて 2.5V まで放電することをいう。

5.5 Electrical Performance 電氣的性能

1

Item 項目	Condition 条件	Specification 規格値
5.5.1 Open-Circuit Voltage 開路電圧	Shipping condition 出荷状態  Measuring condition Measuring temperature : 27±3°C Measuring accuracy : Within ±1mV 測定条件 測定温度: 27±3°C、 測定精度: ±1mV 以内の精度を有する測定器を 使用する。	3.400-3.616V and the OCV shall be within 0.1V on the same cell lot. 3.400V~3.616V 且つ同一ロット内の 電圧差は 0.1V 以内
5.5.2.1 AC Impedance(1) 内部抵抗(1)	After standard charge within 3 days.(1kHz) 標準充電後 3 日以内.(1kHz)	7mΩ~17mΩ
5.5.2.2 AC Impedance(2) 内部抵抗(2)	Shipping condition.(1kHz) 出荷状態(1kHz)	7mΩ~17mΩ
5.5.3.1 Capacity(1) 放電容量(1)	After standard charging, discharge at 0.2ItA(300mA) cut off voltage 2.5V 標準充電後、0.2ItA(300mA) 放電 2.5V 終止	1500mAh or more
5.5.3.2 Capacity(2) 放電容量(2)	After standard charging, Standard discharging 標準充電後、標準放電	1425mAh or more
5.5.3.3 Capacity(3) 放電容量(3)	After standard charging, discharge at 10A(10000mA) cut off voltage 2.5V 標準充電後、10A(10000mA) 放電 2.5V 終止	1350mAh or more
5.5.3.4 Capacity(4) 放電容量(4)	After standard charging, discharge at 20A(20000mA) cut off voltage 2.5V 標準充電後、20A(20000mA) 放電 2.5V 終止	1200mAh or more
5.5.4 Charge/Discharge Cycle 充電放電サイクル	Charge at 4.2V, 4.0A, Cut-off current 100mA<-->Discharge at 10A, 2.5V Cut-off After 600cycles 充電 4.2V,4.0A 100mA終止 <- ->放電 10A,2.5V 終止 600 サイクル後	1013mAh or more
5.5.5 Storage Characteristic 保存特性	After standard charging, stored at 23 °C for 28 days. Remaining capacity from 10A (2.5V cut off) discharging. 標準充電後、23°C- 28 日間保存 10A(2.5Vcut)放電での残存容量	1215mAh or more
	After above measurement, Recovery capacity by discharge at 10A, 2.5V cutoff after standard charge 残存容量測定後、 標準充電、10A(2.5Vcut)放電での回復容量	1283mAh or more
	After standard charging, stored at 45 °C for 28 days. Remaining capacity from 10A (2.5V cut off) discharging. 標準充電後、45°C- 28 日間保存 10A(2.5Vcut)放電での残存容量	1148mAh or more
	After above measurement, Recovery capacity by discharge at 10A, 2.5V cutoff after standard charge 残存容量測定後、 標準充電、10A(2.5Vcut)放電での回復容量	1215mAh or more



<p>5.5.6 Long term Storage characteristic 長期保存特性</p>	<p>After standard Charging, store at 23 °C, 365days. Recovery capacity of standard charging and 10A(2.5V Cut off) discharging. 標準充電後、 23°C- 365 日間保存 標準充電、10A(2.5V Cut Off)放電での回復容量</p>	<p>1215mAh or more</p>										
<p>5.5.7 Discharging Temperature Characteristic 放電温度特性</p> <p>Standard Charging Discharging: 10A Cut-off Voltage: 2.5V 標準充電後、 10A 放電 2.5V 終止</p>	<table border="1"> <thead> <tr> <th>Discharge Temperature 放電温度</th> <th>Capacity 容量</th> </tr> </thead> <tbody> <tr> <td>-10°C</td> <td>945mAh or more</td> </tr> <tr> <td>0°C</td> <td>1080mAh or more</td> </tr> <tr> <td>23°C</td> <td>1350mAh or more</td> </tr> <tr> <td>45°C</td> <td>1350mAh or more</td> </tr> </tbody> </table>	Discharge Temperature 放電温度	Capacity 容量	-10°C	945mAh or more	0°C	1080mAh or more	23°C	1350mAh or more	45°C	1350mAh or more	<p>Refer to the left table 左の表参照</p>
Discharge Temperature 放電温度	Capacity 容量											
-10°C	945mAh or more											
0°C	1080mAh or more											
23°C	1350mAh or more											
45°C	1350mAh or more											
<p>5.5.8 Charging Temperature Characteristic 充電温度特性</p> <p>Charging:4.20V 1.5A, 2.5h Standard Discharging</p> <p>充電: 4.20V 1.5A,2.5h 標準放電</p>	<table border="1"> <thead> <tr> <th>Charging Temperature 充電温度</th> <th>Capacity 容量</th> </tr> </thead> <tbody> <tr> <td>0°C</td> <td>1212mAh or more</td> </tr> <tr> <td>23°C</td> <td>1425mAh or more</td> </tr> <tr> <td>45°C</td> <td>1425mAh or more</td> </tr> </tbody> </table>	Charging Temperature 充電温度	Capacity 容量	0°C	1212mAh or more	23°C	1425mAh or more	45°C	1425mAh or more	<p>Refer to the left table 左の表参照</p>		
Charging Temperature 充電温度	Capacity 容量											
0°C	1212mAh or more											
23°C	1425mAh or more											
45°C	1425mAh or more											

1

## 5.6 Reliability 信頼性

Item 項目	Condition 条件	Specification 規格値
5.6.1 Heat Cycle Test ヒートサイクルテスト	After Standard Charging, 75°C6h ←30min→ -40 °C6h for 10 Cycles. Then storage at 20+/-5°C, 24h. 標準充電後、 75°C6h ←30min→ -40°C6h 10 サイクル その後、20±5°Cに 24h 保管する。	No leakage, No interception 漏液、遮断なきこと
5.6.2 Shock Test 耐衝撃性能	After Standard Charging, P-tile from height of 1.2m. Dropped in Each X,Y and Z for 3 time, with guide like as tube. Discharge at 10A , Cut-off Voltage 2.5V Capacity of the 2nd time.  標準充電後、P タイルへ 高さ 1.2mから XYZ 各 3 回落下(ガイドチューブ使用のこと) 2 回目の 10A 放電 2.5V 終止容量	No leakage, 漏液なきこと  1283mAh or more
5.6.3 Vibration Test 耐振動性能	After Standard Charging, Vibration is to be applied. Discharge at 10A, Cut-off Voltage 2.5V Capacity of the 2nd time. 標準充電後、振動 2 回目 10A 放電 2.5V 終止容量  Sinusoidal Oscillation 正弦振動 10~60Hz, 20.6m/s <sup>2</sup> 60~80Hz, 13.7m/s <sup>2</sup> 80~100Hz, 6.9m/s <sup>2</sup> 100~125Hz, 3.9m/s <sup>2</sup> 5 min. Sweep Each XYZ for 1h 5 分スイープ, XYZ 各 1 時間	No leakage, 漏液なきこと  1283mAh or more

## 6. Identification and Marking (Lot Number Definition : Manufacturing Date of Cells)

セル表示 (ロット番号 : セルの製造日)

The code is printed on a surface of the can, under the tube, at five lines.

セル表示はセル側面に 5 行で印字する。

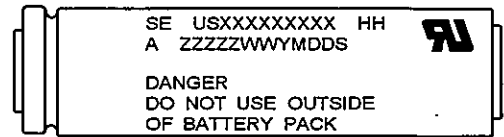

Fig.1

### 6.1 Manufacturer Name (Trade name) 製造社名

SE (Trade name of Sony Energy Devices Corp.)

SE (ソニーエナジー・デバイス株式会社) トレードネーム

### 6.2 Trade Mark (Fig.1 : USXXXXXXXXX) 登録機種名 (Fig.1 : USXXXXXXXXX)

US18650VTC3

### 6.3 Plant (Fig.1 : A for plant code) 製造所 (Fig.1 右記図 : A)

SG or G : Sony Electronics(Singapore) Pte.Ltd.

### 6.4 Specification (Fig.1. : HH for Cell Type) 仕様 (Fig.1 : HH)

C3 : US18650VTC3

### 6.5 Lot Number (Fig.1 : YMDDS for Manufacturing Date of Cells)

ロット、セル製造年月日 (Fig.1 : YMDDS)

Lot Number (Fig.1 : YMDDS for Manufacturing Date of Cells)

ZZZZZ : Serial No.

Y : Year            Supposing the year '15 as X, the year '16 as Y, the year '17 as Z, the year '18 as A, Every next year is counted as B, C, ... (Using an Alphabet letter)

M : Month        January as A, the consecutive month as B, C, ... (Using an Alphabet letter)

D : Day           01, 02, . . . . 29, 30, 31        (Using figures)

S : Electrode History    A, B, C, ...                            (Using an Alphabet letter)

任意のアルファベットまたは数字

シリアル番号 : ZZZZZ

年 Y : 2015 年を X, 2016 年を Y, 2017 年を Z, 2018 年を A として

年毎に B, C, ..... (アルファベット)

月 M : 1 月を A, として月毎に B, C, ..... (アルファベット)

日 DD : 1 日を 01 として数字にて示す ..... (数字)

電極履歴 S : 電極の履歴を示す。 A, B, C, ..... (アルファベット)

### 6.6 UL Marking UL マーク (Fig.2 : Recognition Mark)



Fig.2

### 6.7 2 Dimensional Code 2 次元コード (Fig.3)

The code is on the surface of the tube

セル側面チューブ上に印字



Fig.3

1

6.8 Warning Message (Fig.1)

DANGER DO NOT USE OUTSIDE OF BATTERY PACK

Display on the surface of the cell.

セル側面に印字する

7.Outline 外形

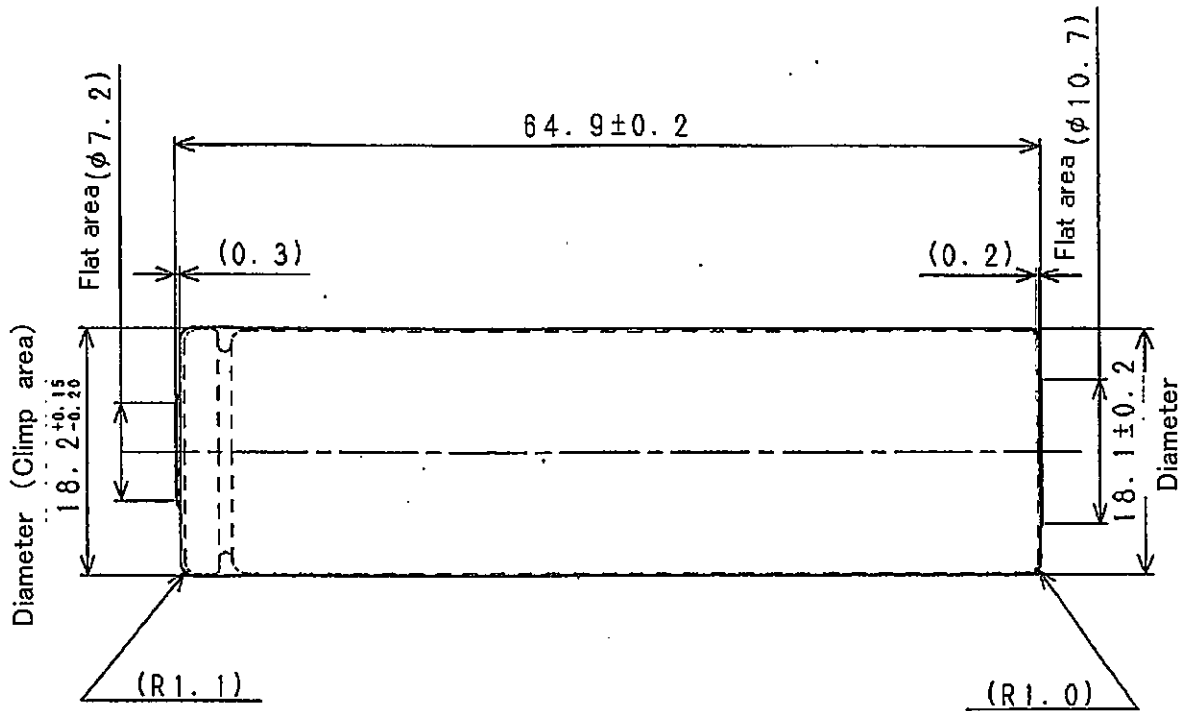

ポトム部タブ溶接禁止エリア  
 Prohibited area tab welding the bottom portin  
 右図のように、中心部から $\phi 3$ の範囲は溶接しないこと  
 As shown in the figure on the right,  
 don't weld in the range of  $\phi 3$  from center

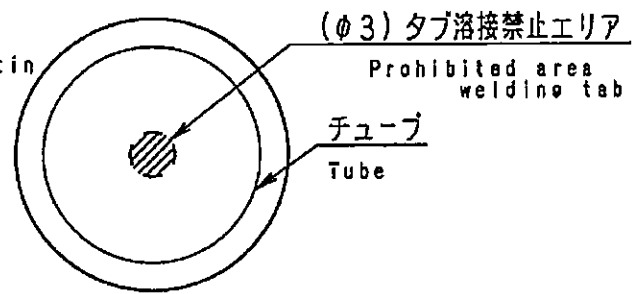

## 8. Caution 注意事項

Caution on usage of Lithium-Ion Rechargeable Battery.

リチウムイオン電池を取扱うための注意事項

### 8.1 Caution for installing the battery into the pack パック組立

\*Do not combine the different Lot Number cell (the Last 5 letters and figure) into the pack  
同一パック内に異なるロットナンバー(下5桁)のセルを混在させないこと

### 8.2 Caution for the battery and the pack 単セルおよびパックに関する注意事項

#### 8.2.1 Charge 充電

\*It shall be Constant Current-Constant Voltage (CC-CV) charging method.  
定電流定電圧(CC-CV)充電方式を推奨いたします

#### 8.2.2 Discharge 放電

\*It shall avoid discharging less than 2.5V.  
放電時のカットオフ電圧は 2.5V を推奨します

#### 8.2.3 Design of battery pack バッテリーパック設計

\*It shall be the shape which cannot be connected easily to any charger other than the dedicated charger.

専用充電器以外で容易に充電できないようなコネクタ形状にすること

\*It shall have the structure which cannot be connected easily for end user to apply for another purpose.

エンドユーザーが他の目的で容易に充電できないような構造にすること

\*It shall have the terminals or function which cannot easily cause external short circuit (such as chain short by necklace).

容易に外部短絡(ネックレス等によるチェーンショート)を引き起こさないような端子形状や構造とすること

\*It shall not be short easily by effect of vibration or drop due to contact of internal writing materials to battery.

振動や落下によりパック内部構造由来のショートが容易に起こらないように配慮すること

#### 8.2.4 Protection Circuit 保護回路

\*The protection circuit shall be installed in the battery pack or the charger.

バッテリーパック、充電器には保護回路を設置すること

\*The battery system must possess four types of protective circuits as follows.

バッテリーシステムには以下4つの保護回路を有すること

##### 8.2.4.1 Over charging protective circuit by each block cell voltage monitoring

各ブロック電圧モニターによる過充電保護回路

By each block cell voltage monitoring, the over charging protective circuit shall operate at less than 4.250V/cell.

過充電保護回路は、各ブロック電圧モニタリングシステムにより、パック中の全セルに対し 4.250V/cell 以下で作動すること

##### 8.2.4.2 Over discharging protective circuit by each block cell voltage monitoring

各ブロック電圧モニターによる過放電保護回路

By each block cell voltage monitoring, the over discharging protective circuit shall operate at 1.5V/cell to 2.5V/cell.

過放電保護回路は、各ブロック電圧モニタリングシステムにより、パック中の全セルに対し 1.5V/cell ~ 2.5V/cell で作動すること

### 8.2.4.3 Over current protective circuit 過電流保護回路

The over current protective circuit shall operate charging at less than 10A.

充電時の過電流保護回路は 10A を超えるまでに作動すること

The over current protective circuit or device shall operate discharging less than 30A.

放電時の過電流保護は 30A を超えるまでに作動すること

If the over 30A discharge occur, the allowable time of operating over current protection comply with the below table.

30A を超える放電が発生する場合、過電流保護作動までの許容時間は下記表に従うこと

Discharge current 放電電流	30~40A	~50A	~60A	~80A	~100A
Time 時間	<45sec.	<25sec.	<15sec.	<6sec.	<4sec.

### 8.2.4.4 Over temperature protective circuit at cell surface temperature

セル表面温度における温度保護回路

The over temperature protective circuit at high temperature side shall operate discharging until 80degC. (Including overshoot)

放電時、高温側ではセル表面温度が 80°Cになる前に温度保護が作動すること(オーバーシュート含む)

The over temperature protective circuit at high temperature side shall operate charging at until 60degC. (Including overshoot)

充電時、高温側ではセル表面温度が 60°Cになる前に温度保護が作動すること(オーバーシュート含む)

The over temperature protective circuit at low temperature side shall operate charging below 0degC.

充電時、低温側ではセル表面温度が 0°C以下で温度保護が作動すること

### 8.2.5 Prohibition of over discharge state. 過放電状態での禁止事項

In the situation that the battery becomes over discharged to the point where it becomes less than or equal to 1.0V, it is prohibited to charge such battery.

1.0V 以下になるまで放電した状態で充電することを禁止する

### 8.2.6 Cell Configuration 接続セル数

The cell configuration in the battery pack is to 2 parallels 10 series at the maximum.

パック内接続セル数は、最大 2 並列 10 直列までとする

## 8.3 Storage 保存

\*The recommendation is SOC 20~50% for long-term storage.

長期保存時の推奨は SOC20~50%です。

\*It shall be kept in dry condition of low humidity, especially be free from high temperature (45degC or more). (Recommended Temperature 20degC. , Humidity 50% or less. )

保存環境は、低湿度の乾燥状態を維持すること。特に 45°C以上とならないこと

(推奨温度;20°C、推奨湿度;50%以下)

\*Do not store the battery near heat sources, nor in a place subject to direct sunlight.

熱源の近く 或いは、倉庫内でも直射日光が当たる場所では保管しないこと

#### 8.4 Prohibition Clause 禁止事項

- \*Do not use the battery for any purpose other than the application and the battery pack specified in the Pack Check Sheet for Sony Li-ion Cell (Category; Power Technology) of such battery.  
パックチェックシートにおいて予め取り交わした用途・電池パック以外への使用禁止
- \*Do not resell the battery.  
電池を転売しないこと
- \*Do not throw the battery into fire, nor heat the battery.  
電池を温めたり、火に投げ入れたりしないこと
- \*Do not disassemble nor modify the battery.  
電池を分解改造しないこと
- \*Do not leave the battery in a place of high temperature (60degC or more).  
高温(60℃以上)に置かないこと
- \*Do not use the battery in a place of high temperature (60degC or more).  
高温(60℃以上)で使用しないこと
- \*Do not expose the batteries to water or moisture.  
水濡れのなきこと
- \*Do not add strong shock, nor drop the battery.  
強い衝撃を与えたり、落下させないこと
- \*Do not solder leads directly to the battery body.  
セルに直接ハンダ付けしないこと
- \*Do not short (+) and (-) terminal of the battery with a kind of metal.  
プラス端子とマイナス端子を金属等で短絡させないこと
- \*Do not reverse charge the battery.  
逆充電しないこと
- \*Do not penetrate the battery with a nail etc., nor make a hole in the battery.  
釘を刺したり、穴を開けたりしないこと
- \*Do not put the battery into a microwave oven, or high pressure container.  
電子レンジや高圧容器内に入れないこと

#### 8.5 Note 補足

If any doubt or inconvenience regards this specification arises, modification and revision shall be only made per mutual agreement.

仕様に関して、なんらかの疑問・不便が発生した場合は、双方協議の上修正対応する。

When production location of the cell is planned to be changed or added, we'll inform and provide of necessary evaluation data beforehand to get customer's approval.  
セルの製造事業所追加・変更は、Sony の評価データ提出をもって、実行させていただきます。

9. Packing 梱包仕様

9.1 Packing Instruction 梱包仕様図

9.1.1 Boat transport specifications

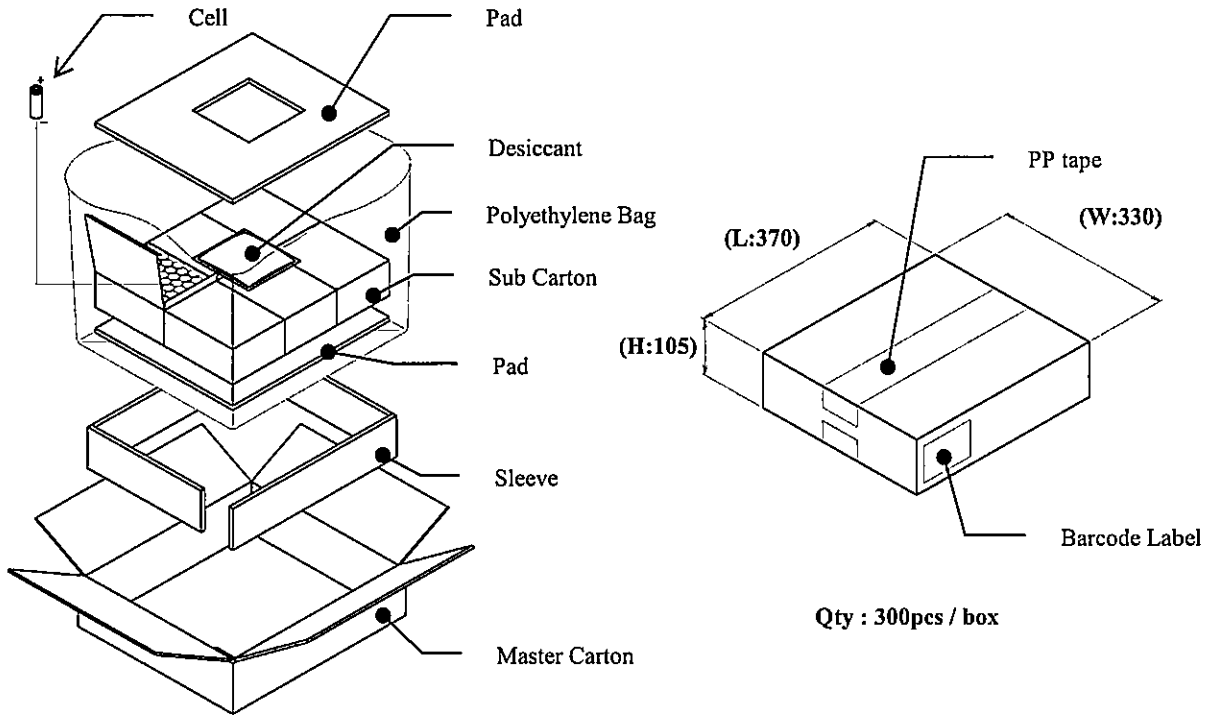

9.1.2 Air transport specifications

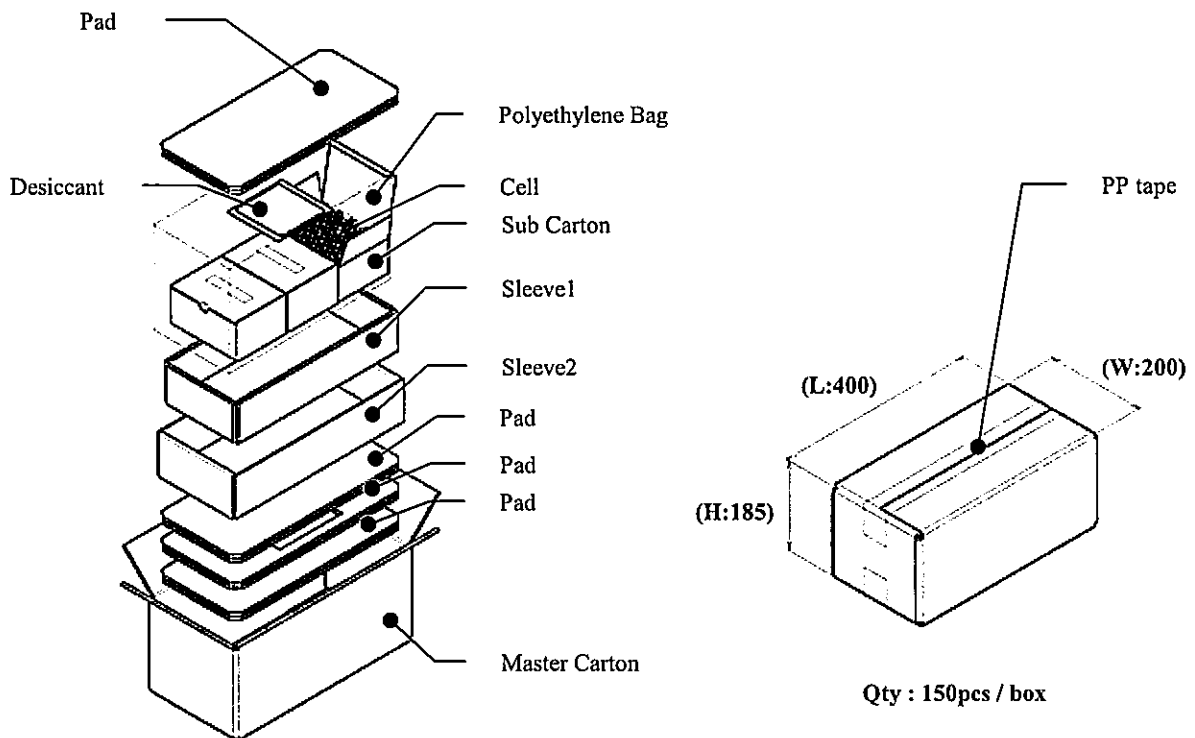







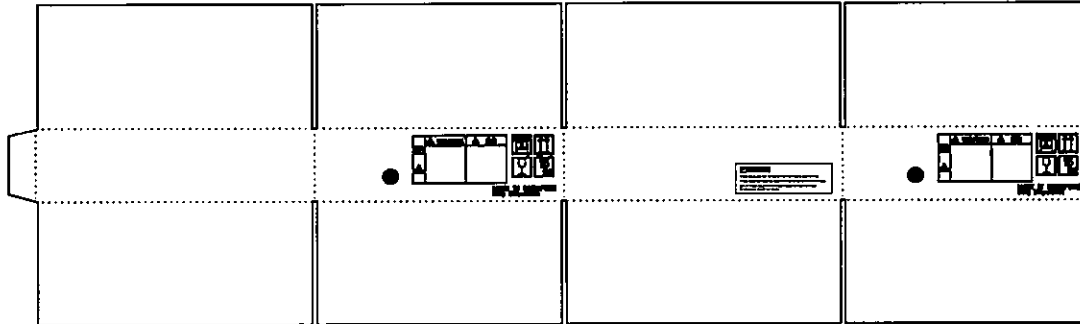



## 9.2 Printing Instruction for Master Carton マスターカートン印刷仕様

### 9.2.1 Boat transport specifications





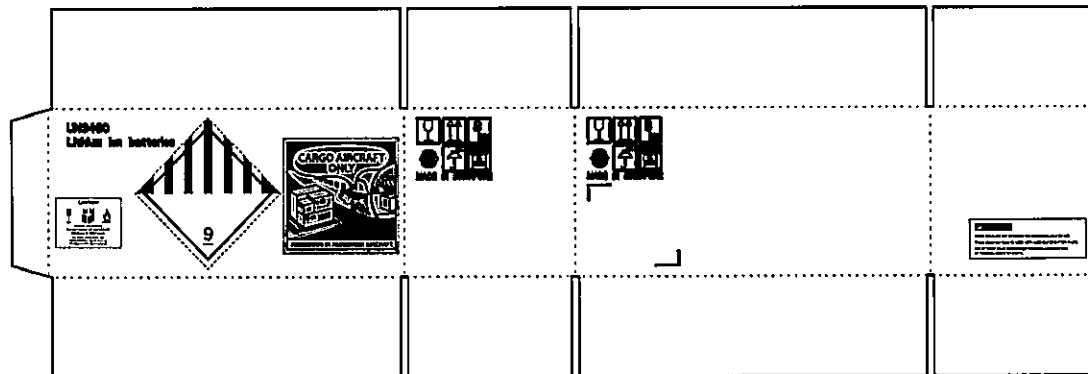

	 <b>CAUTION</b> Lithium ion rechargeable batteries inside the lithium metal. Do not damage or puncture this package. If package is damaged, batteries must be quarantined, inspected, and tracked. For emergency: info@sony.com 1-800-674-9359	 <b>注意</b> リチウムイオン二次電池が内蔵されています。 破損や穿孔、衝撃は厳禁です。 破損や穿孔、衝撃を受けた場合は、危険物として取り扱ってください。 緊急時連絡先: info@sony.com 1-800-674-9359	 <b>6</b> 	 <b>DANGER</b> THESE CELLS ARE NOT INTENDED FOR INDIVIDUAL SALE OR USE. THESE CELLS MAY ONLY BE USED WITH ASSEMBLY OF BATTERY PACKS. USE OF THESE CELLS INDIVIDUALLY PRESENTS A SERIOUS RISK OF PERSONAL INJURY OR DEATH.
	 			

**MADE IN SINGAPORE**  
Sony Corporation

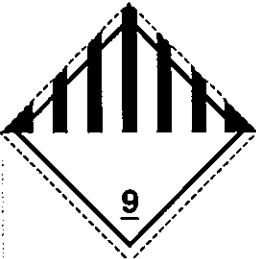
### 9.2.2 Air transport specifications

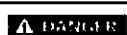

UN3480 Lithium ion batteries			
	 <b>DANGER</b> THESE CELLS ARE NOT INTENDED FOR INDIVIDUAL SALE OR USE. THESE CELLS MAY ONLY BE USED WITH ASSEMBLY OF BATTERY PACKS. USE OF THESE CELLS INDIVIDUALLY PRESENTS A SERIOUS RISK OF PERSONAL INJURY OR DEATH.		







**MADE IN SINGAPORE**

### 9.3 Parts name marking 品名表示







A part name is marked on the bar code label of master carton. This bar code label is stuck to one places of master carton.

品名はマスターカートンの一面に貼ったバーコードラベルに表示する。

#### 9.3.1 Boat transport specifications

MODEL NAME USS180BMVTC3(AE)	MODEL CODE 
MODEL CODE F49942546	***** CELL Lot No. 
CELL NAME US18650VTC3	MASTER CARTON No. 
CELL CODE 1-853-058-31	***** MASTER CARTON Qty. 
CELL Lot No. *****	PACKING DATE 
SUPPLIER Sony Corporation	***** CUSTOMER CODE 
	*****

#### 9.3.2 Air transport specifications

MODEL NAME USS180BMVTC3(E)	MODEL CODE 
MODEL CODE F49942547	***** CELL Lot No. 
CELL NAME US18650VTC3	MASTER CARTON No. 
CELL CODE 1-853-058-31	***** MASTER CARTON Qty. 
CELL Lot No. *****	PACKING DATE 
SUPPLIER Sony Corporation	***** CUSTOMER CODE 
	*****

## 9.4 Packing Instruction for Pallet

### 9.4.1 Boat transport specifications

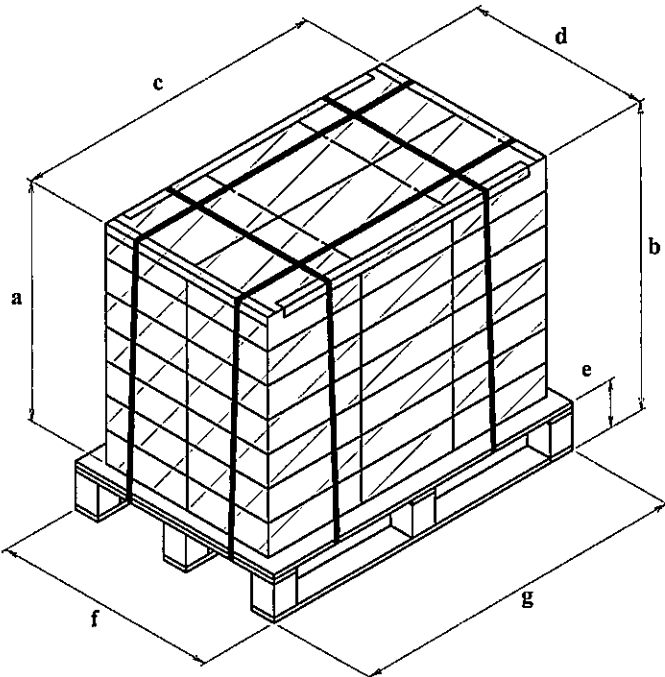

Size (mm)

a : 735  
 b : 879  
 c : 1113  
 d : 662  
 e : 144  
 f : 800  
 g : 1200

### 9.4.2 Air transport specifications

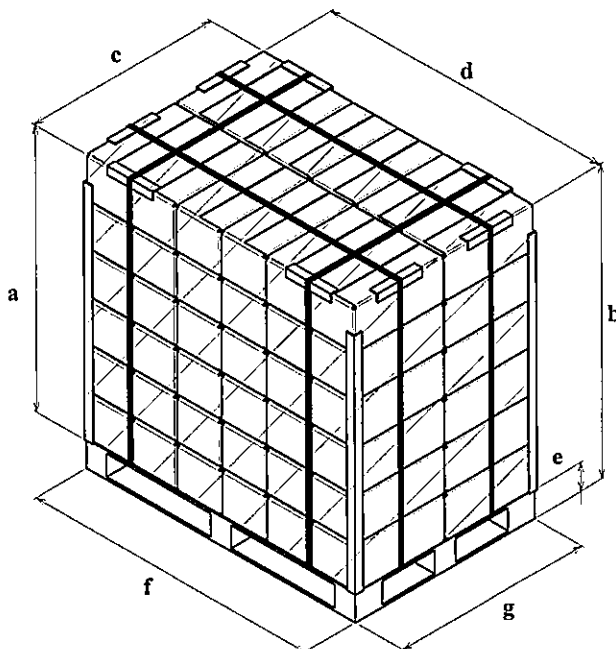

OVER PACK

OVERPACK Label

UN3480  
Lithium ion batteries

UN3480 Label



CAO Label



CLASS9 Label



ICAO Label

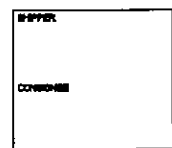

SHIPPER, CONSIGNEE Label

\* Labels are affixed on the surface of the stretch film.  
 ラベルはストレッチフィルムの上に貼り付けられます。

Size (mm)

a : 1110  
 b : 1254  
 c : 800  
 d : 1200  
 e : 144  
 f : 1200  
 g : 800